

# Eclipse Winnox

## Burners

Model WX0500

Version 2

Parameter		Specifications	
<b>Blower Type</b>		<b>Packaged Blower</b>	<b>Remote Blower</b>
<b>Maximum Input, BTU/hr (kW)<sup>1</sup></b>  <i>Contact factory for chamber pressures outside the given range, or varying chamber pressure conditions.</i>	Chamber Pressure "w.c. (mbar)	Nominal (50Hz and 60Hz)	Pressure at Air Inlet 1 psig (70 mbar)
	-5.0 (-12.5)	5,560,000 (1630)	6,720,000 (1970)
	-3.0 (-7.5)	5,340,000 (1560)	6,440,000 (1890)
	0.0	5,000,000 (1470)	5,990,000 (1760)
	1.0 (2.5)	4,880,000 (1430)	5,830,000 (1710)
2.0 (5.0)	4,760,000 (1390)	5,670,000 (1660)	
<b>Minimum Input, BTU/hr (kW)</b>		570,000 (170)	570,000 (170)
<b>Fuel Inlet Pressure at Ratio Regulator, "w.c. (mbar)<sup>2</sup></b>	Maximum	55 (138)	69 (172)
	Minimum	28 (70)	42 (103)
<b>Maximum Chamber Temperature, °F (°C)</b> <i>Tube and plug temperatures should be reduced 150°F when using propane or butane.</i>		Standard combustion tube: 1300 (705) High temp. combustion tube: 1550 (845) Refractory plug: 1800 (985) <sup>3</sup>	
<b>Flame Length</b>	Alloy Tube	Flame is inside tube at all times	
<b>Excess Air, % at High Fire</b>		40% - 70%	
<b>Pipe Connections</b>		NPT or BSP connections available	
<b>Flame Detection</b>		Flame rod or UV scanner	
<b>Fuels</b> <i>For any other mixed gas, contact Eclipse Inc.</i>		Natural gas, propane, butane <sup>4</sup>	
<b>Blower Motor Power, Hp</b>		7.5	-
<b>Weight, lbs (kg)<sup>5</sup></b>	Alloy Tube	505 (229)	338 (153)
	Refractory Plug	459 (208)	292 (132)
<b>Approvals</b>			

<sup>1</sup> Maximum inputs for packaged blower versions are given for the standard combustion air blower without an inlet air filter.

<sup>2</sup> For proper performance, this pressure must be kept constant across the burner operating range.

<sup>3</sup> See page 3 of this datasheet and Installation Guide 111 for "Refractory Plug Only" installation.

<sup>4</sup> See Design Guide 111 for more information about typical fuel composition and properties.

<sup>5</sup> All weights are approximate.

- All inputs are based on gross calorific values and standard conditions: one atmosphere, 70°F (21°C).
- All information is based on laboratory testing. Different chamber size and conditions will affect data.
- Eclipse reserves the right to change the construction and/or configurations of our products at any time without being obliged to adjust earlier supplies accordingly.

## Performance Graphs

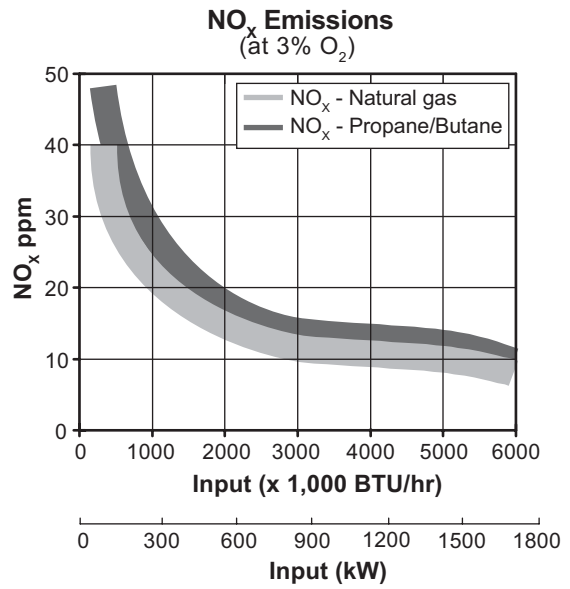
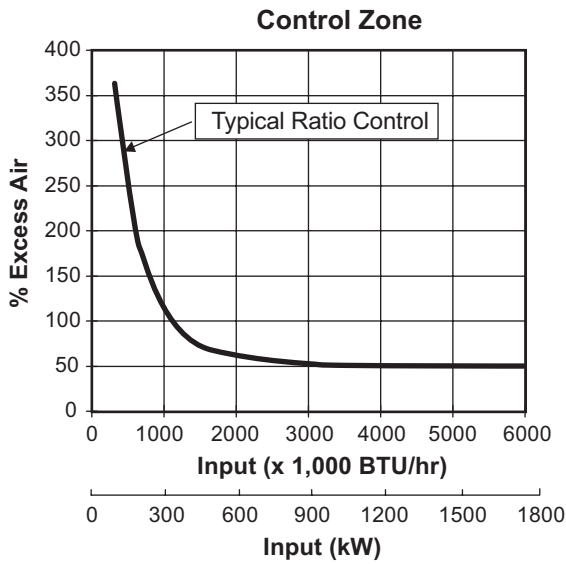

### Fuel/Input Measurement

System design must include fuel flow measurement upstream of the burner. Eclipse recommends its 8-5 FOM (Fuel Orifice Meter) assembly number 302087-5 for natural gas. See Bulletin 930 for details.

### Secondary By-Pass Fuel Setting:

Fuel	$\Delta P$ "w.c. (mbar)*
Natural Gas	8.0 (20.0)
Propane	2.0 (5.1)
Butane	2.0 (5.1)

\*Measured between Tap "E" and the chamber @ low fire.

**NOTE:** Input at low fire changes with ratio regulator adjustment.

### NO<sub>x</sub> emission data is given for:

- Ambient combustion air (~70°F, 20°C)
- Less than 1000°F (540°C) firing chamber
- Minimal process air velocity
- Low fire input adjusted to 570,000 BTU/hr (167 kW)
- Neutral chamber pressure

### Emissions are influenced by:

- Chamber conditions
- Fuel type
- Firing rate
- Ratio regulator adjustments
- Combustion air temperature

CO emissions are largely influenced by chamber conditions. Contact your local Eclipse representative for an estimate of CO emissions on your application.

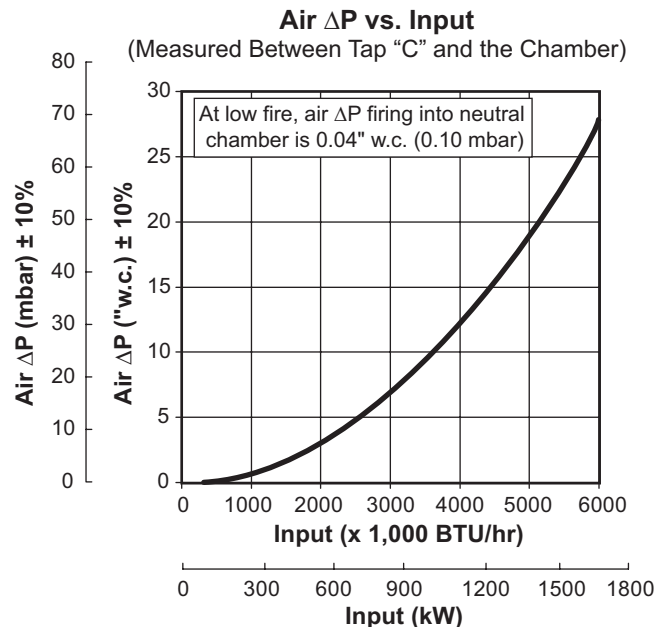

## Dimensions in mm (inches) Packaged Blower

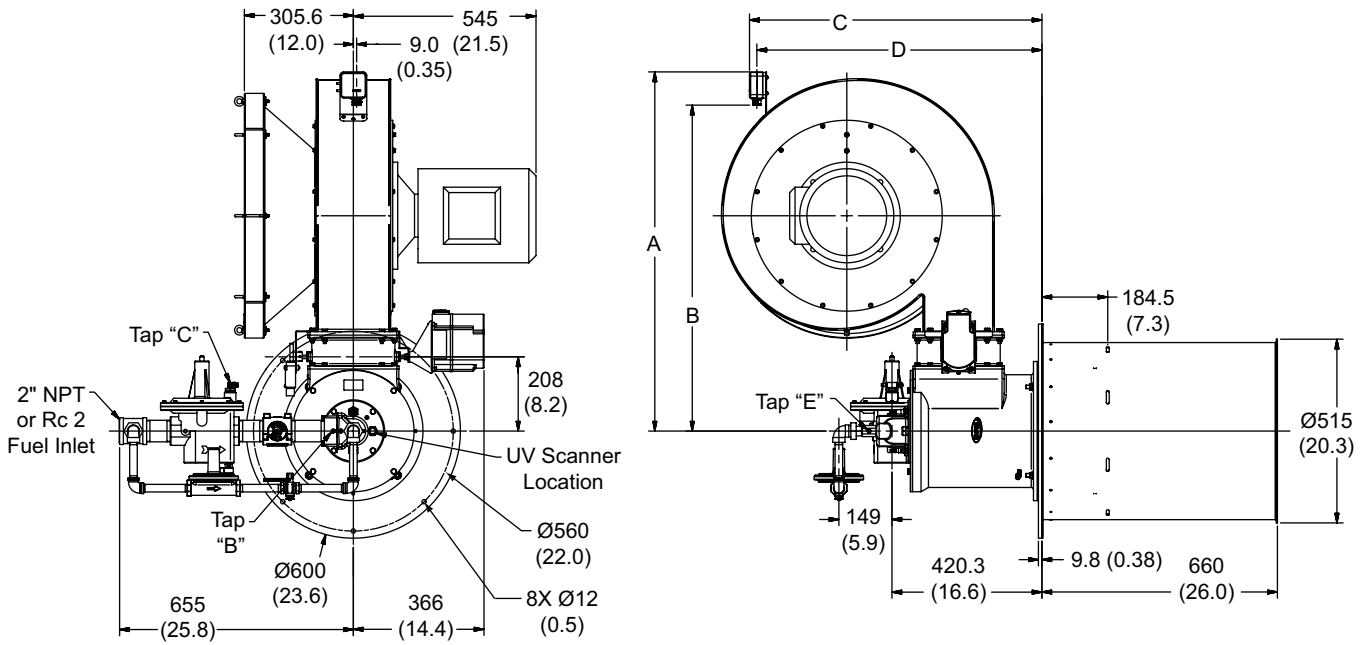

Blower Type		
	60 Hz	50 Hz
Dimensions in mm (inches)		
A	924 (36.4)	1007 (39.6)
B	830 (32.7)	914 (36.0)
C	744 (29.3)	819 (32.3)
D	723 (28.5)	799 (31.5)

### Refractory Plug

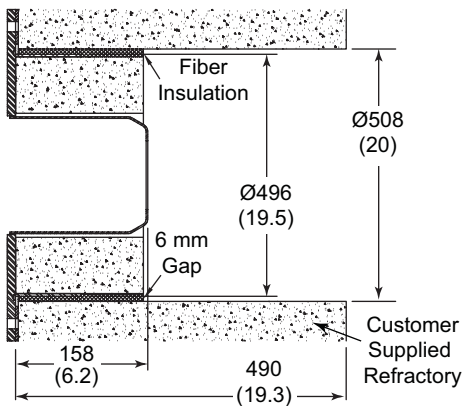

### Pilot Ready Option (Shown with remote blower option)

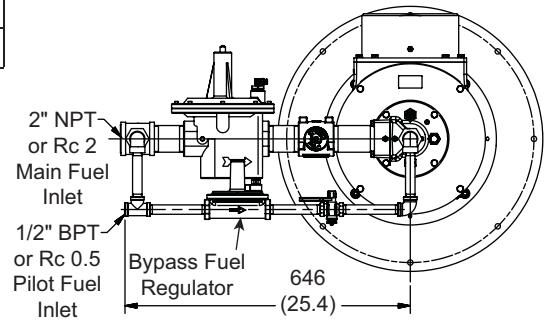

### Remote Blower

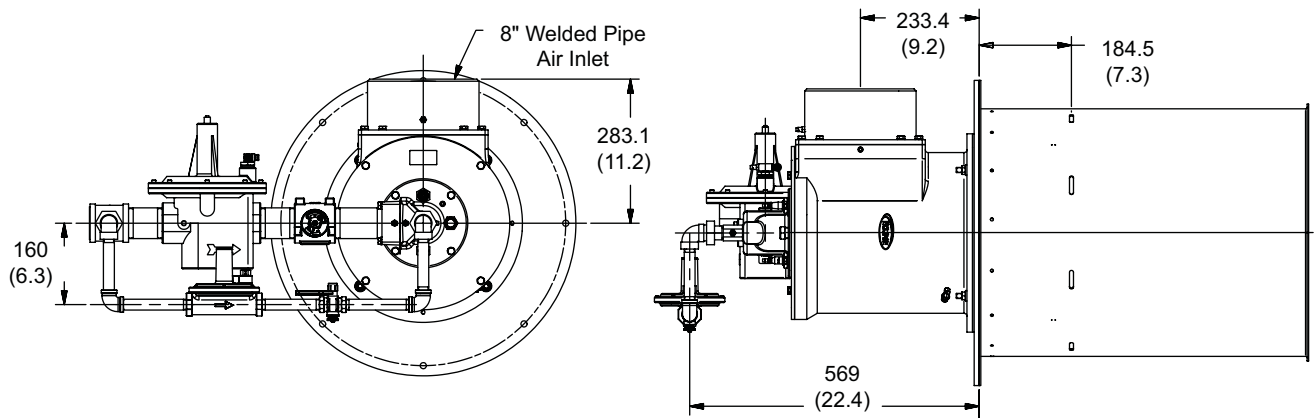



**Offered By:**

Power Equipment Company  
2011 Williamsburg Road  
Richmond, Virginia 23231  
Phone (804) 236-3800  
Fax (804) 236-3882

---

[www.peconet.com](http://www.peconet.com)